

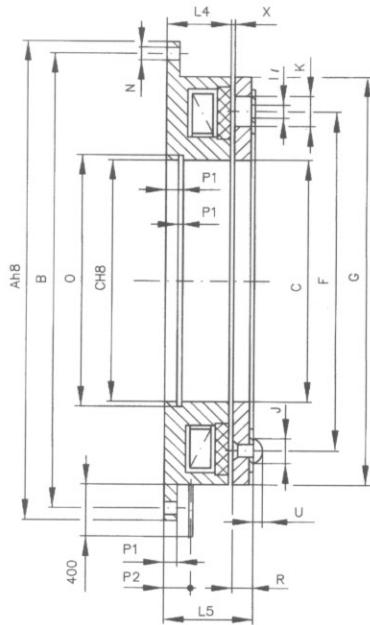

POHONY • DRIVES • ANTRIEBE



## ELECTRICALLY ACTUATED DISC CLUTCH EKP

IS DESTINATED FOR EQUIPMENT WHERE HIGH FREQUENCY OF SWITCHING IS DEMANDED WITH REQUEST FOR SHORTENING OF WORKING CYCLES AND INCREASING OF WORKING SPEED FOR REASONS - TO INCREASE THE RUNNING OUTPUT OF MACHINES. IT IS USED MOSTLY ON PACKING, TEXTILE AND FOOD EQUIPMENT. IT WORKS ONLY IN NON-LUBRICATED ENVIRONMENT.

## MAIN TECHNICAL DATA AND DIMENSIONS (mm)

SIZE		4	6,3	10	16	25
RAT.TORQUE Mn	Nm	40	63	100	160	250
STAT. TORQUE M max		48	75	120	185	290
CURRENT	A	0.87	1.02	1.39	1.46	1.79
INPUT	W	21	24.7	33.4	35	43
A	mm	144	158	182	210	235
B		132	145	166	195	218
C		55	62	75	90	100
F		93	104	112	134	150
G		119	132	149	178	200
I		3x5.1	3x6.1	3x8.1	3x8.1	3x10.1
J		8.5	10			
K		11.5	15	20	20	25
N		4x6.5	4x6.5	4x8.5	4x8.5	4x8.5
O		58	65	78	93.5	103.5
L5	mm	29.5	32			
L4		22	24	26	30	36
P1		3	4	4	5	5
P2		7	8	8	9	10
R		7.2	7.7			
S		5.15	6.15	6.65	6.65	7.15
S1		2.15	2.15	2.65	2.65	3.15
U		4.5	5.4			
X		0.3	0.3	0.3	0.3	0.4
MOMENT OF INERTIA		kg.m <sup>2</sup>	9.6.10 <sup>-4</sup>	2.06.10 <sup>-3</sup>	2.83.10 <sup>-3</sup>	6.47.10 <sup>-3</sup>
MAXIMUM ROTATIONS	min <sup>-1</sup>	3000	3000	2600	2200	1800
WEIGHT	kg	1.55	2.3			

The brake EKP consists of driven member and fixed magnet body. The driven member is formed by the armature plate with riveted on shaped spring. In the spring there are 3 openings made for gripping, on the driven member of the equipment. The spring serves for brake disengaging, for separating of the armature plate from the magnet body and it secures its position in disengaged state. In the fixed magnet body there is field coil sealed for control voltage 24 VDC. The control voltage is carried to free conductor of the magnet body. For improvement of friction properties an asbestos-free friction material is placed at the face of the magnet body. In the flange of the body 4 openings are made for gripping on the immobile machine part.

The brake EKP is not adjusted. The air gap between the armature plate and the magnet body must be secured by means of the construction of following members of equipment. It has nearly no residual moment. In the disengaged state it does not wear-out and does not heat up. It can run therefore for an unlimited time disengaged.

### DATA FOR ORDER:

- Size and type
- Number of pieces
- Voltage
- Climatic conditions



**PSP POHONY a.s.**

750 53 PŘEROV • CZECH REPUBLIC

TEL. 0641/23 36 30, 23 36 33

FAX 0641/20 31 82, 20 31 60



Quality system certified  
according to DIN ISO 9001