

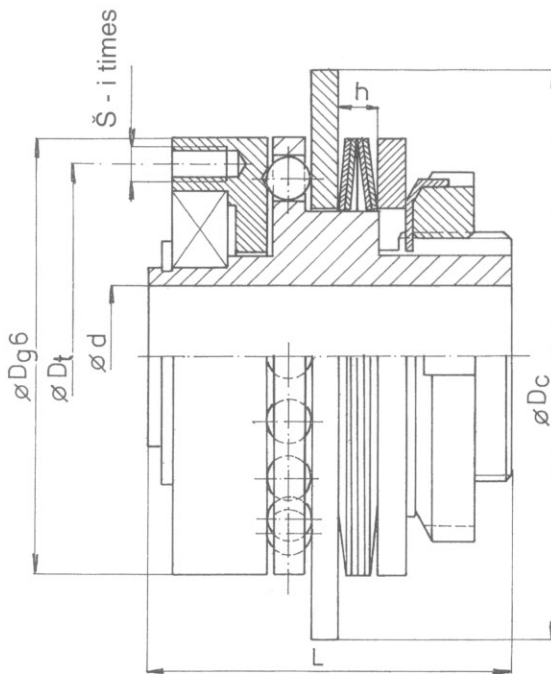

POHONY • DRIVES • ANTRIEBE



BALL OVERLOAD RELEASE CLUTCH SKU

AUTOMATIC BALL OVERLOAD RELEASE CLUTCH WITH BELLEVILLE WASHER IS USED IN DRIVING WHICH MUST BE SECURED AGAINST OVERLOAD. IN THE COURSE OF NORMAL OPERATION CLUTCHES WORK AS A FAST, INFLEXIBLE COUPLING. THEIR FUNCTION STARTS AT THE MOMENT WHEN THE EQUIPMENT IS OVERLOADED BECAUSE OF DEFORMATION OR EVEN MECHANICAL FAILURE OF SOME EQUIPMENT COMPONENT. DRIVING AND DRIVEN HALF OF THE CLUTCH TURNS FREE ONE AGAINST ANOTHER, BECAUSE THE AXIAL FORCE COMPRESSES BY MEANS OF BALLS THE BELLEVILLE WASHER PACK.

TECHNICAL DATA

Clutch		1	2	3	4	5	6
SKU							
Parameter							
Breaking moment	M_{\min} (Nm)	1	2	4	9	20	40
Breaking moment	M_{\max} (Nm)	2	4.5	9	20	50	70
Hub bore min/max	\varnothing dH7 (mm)	6/14	9/16	12/22	16/32	18/35	24/48
Length	L (mm)	45	50	65	80	85	105
Diameter	\varnothing Dg6 (mm)	62	62	82	102	108	132
Diameter	\varnothing D _t (mm)	54	55	72	88	94	116
Worm	Š	M5	M5	M5	M5	M6	M8
	- i times	- 4 times	- 4 times	- 4 times	- 4 times	- 6 times	- 6 times
Speed (r.p.m.)	n_{\max}	1500	1500	1500	1500	1500	1500
Weight	G (kg)	0.65	0.85	2.1	4.7	5.9	10.6
Diameter	\varnothing D _c (mm)	70	80	105	135	170	180

Ball overload release clutches protect the mechanical equipment against undesirable overload. In standard operation clutches work as a fast, inflexible coupling, but it is only up to the moment when the transmitted torsion moment unexpectedly and extraordinarily increases. This pulse makes that driving and driven halves of clutch turns free one against another. The reason that the balls are forced out from axial bearing pits. This causes shift of pressure disk, compression of Belleville washer pack and the signal from contactless path indicator stops the drive of equipment. After the increased twisting moment stops, whole equipment sets itself into normal condition. Belleville washer pack presses all balls back into axial bearing pits in flange. Overload release clutch serves as fast clutch again. Pressure setting Belleville washer packs is performed prior the equipment is put into operation, but if necessary, it is possible tighten the clutch after the equipment set is in rest.

Contactless path indicator watches lock-out of the clutch and it is placed near pressure plate (it is not included into supply). The change of air gap recorded as electric pulse which causes disconnection of equipment from mains. It is recommended contactless path indicators BES516-324-SA26 produced by Balluf, FRG.

ORDERING DATA:

- pieces of clutches
- type and size of clutch
- bore of hub \varnothing dH7
- breaking twisting torque (M_{\max} , M_{\min})



PSP POHONY a.s.
 KOJETÍNSKÁ 71 • 750 53 PŘEROV
 CZECH REPUBLIC
 TEL.: ++420(0)641/23 34 35, 23 20 04
 FAX: ++420(0)641/23 25 34, 36 69



**Quality system certified
 according to DIN ISO 9001**